

We want to grow with you



FIXUS D

Checking and glazing unit



Checking and glazing unit *FIXUS D*



FIXUS D XL

- For fast and accurate assembly of windows and doors in production lines.
- Synchronous move and clamping for high accuracy of angles.
- Both clamping bars are pneumatically retractable below the table surface directly at the place of element clamping.
- Ergonomic working due to pneumatic height adjustment.
- Another unit dimension on demand.

Ord. Nr.	Name	Description
91-ZSA 210 005	FIXUS D-023022-B	Checking and glazing unit – double sided – height adjustment
91-ZSA 310 000	FIXUS D-023022-B-XL	Checking and glazing unit – double sided – height adjustment – XL



Retracted clamping bars

- stable and solid construction
- stepless pneumatic height adjustment up to 500mm
- both clamping bars are pneumatically retractable below the table surface



Operating elements

- simple foot pedal control
- integrated roller conveyor with steel rollers
- height and angle alignment with line by adjustable feet

FIXUS D max. 2600 mm - min. 500 mm
 FIXUS D XL max. 3400 mm - min. 620 mm

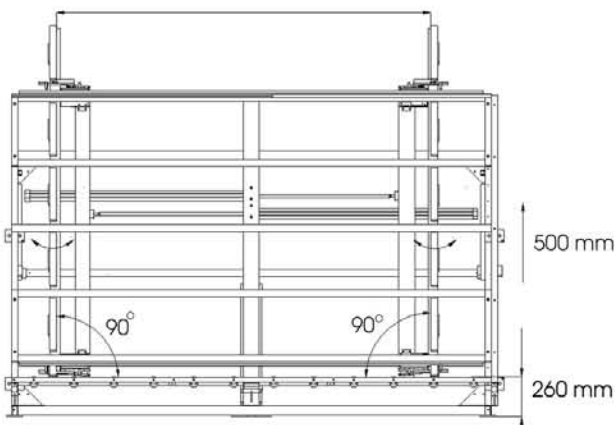

FIXUS D	a = 2600 mm b = 100 mm c = 2200 mm	6- 8 bar	a = 3200 mm b = 850 mm c = 2530 mm	400 kg
FIXUS D XL	a = 3400 mm b = 100 mm c = 2200 mm	6- 8 bar	a = 3900 mm b = 850 mm c = 2530 mm	610 kg